



STANDART MAKİNA ŞASESİ İMALAT FORMU

FİRMA ADI		FÖY NO		BOYA
ŞANTİYE ADI		SİPARİŞ TARİHİ		
ADET		TESLİM TARİHİ		

MAKİNA ÖZELLİKLERİ	
MAKİNA MARKASI:	
MAKİNA MODEL:	
KAPASİTE (KİŞİ):	
A - MAKİNABAĞLANTI ARASI	
B - MAKİNA - KASNAK YATAK BAĞ	

ŞASE ÖZELLİKLERİ (mm)			
C: YÜKSEKLİK		KOLON NPU (G) ***	
D: GENİŞLİK		KIRIŞ NPU (H) ***	
E: DERİNLİK			
F: ÜST NPU ***			

NOTLAR :

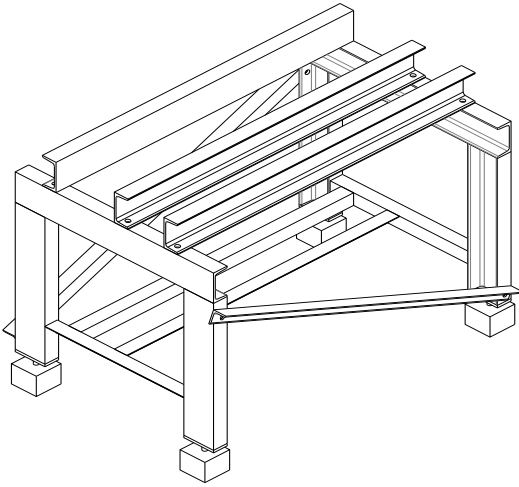
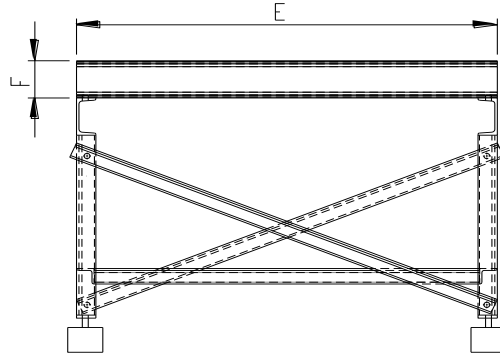
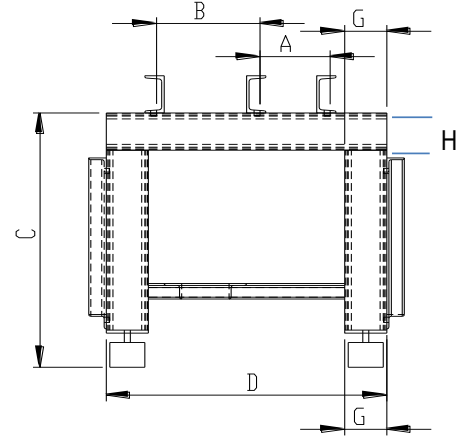

Hazırlayan Onayı:

Kalite Kontrol Onaylayan

TEKNİK BİLGİLER DOĞRULUĞUNU ONAYLAYINIZ

Tarih / Kaşe / İmza

REVİZYON TARİHİ:

REVİZYON NO: